

Series 240

General Purpose

DC LVDTs

上海江晶翔电子有限公司

The Series 240 DC-DC LVDTs are an integrated package consisting of a precision linear variable differential transformer, a solid state oscillator, and a phase-sensitive demodulator. The transducer is designed for excellent linearity, infinite resolution, and high sensitivity. Input and output circuits are electrically isolated from each other and from the coil assembly housing, making them usable directly in floating or ground return systems. DC indicators, recorders, and control systems can usually be driven directly by the large DC output. The core, when displaced axially within the coil assembly, produces a voltage change in the output directly proportional to the displacement.

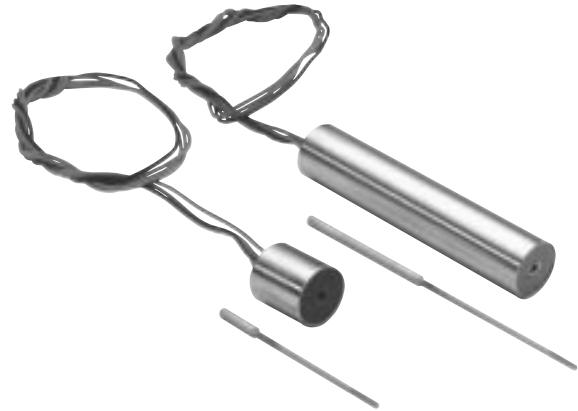

KEY FEATURES

- Ranges from $\pm 0.05''$ to $\pm 4.0''$
- Non-linearity $< 0.5\%$
- Stainless Steel Construction
- 6 to 30 VDC Excitation

SPECIFICATIONS - ELECTRICAL

MODEL NUMBER	0240-00000	0241-00000	0242-00000	0243-00000	0244-00000	0245-00000	0246-00000	0246-00005	
WORKING RANGE, \pm Inches (mm)	0.050 (1.27)	.100 (2.54)	.250 (6.35)	.500 (12.7)	1.00 (25.4)	2.00 (50.8)	3.00 (76.2)	3.00 (76.2)	
MAX. USABLE RANGE, \pm Inches (mm)	0.075 (1.78)	.150 (3.75)	.375 (9.53)	.750 (19.1)	1.50 (38.1)	2.75 (69.8)	3.25 (82.5)	4.00 (101)	
INPUT, VDC	6.0 Min. to 30 Max.							9.0 Min. to 30 Max.	
NOMINAL F.S. OUTPUT, \pm VDC with unloaded output									
@ 6 VOLT INPUT	1.3	2.4	1.8	3.1	4.6	3.9	3.3	N/A	
@ 15 VOLT INPUT	3.4	6.4	4.8	8.3	12.1	10.2	8.7	10	
@ 24 VOLT INPUT	5.5	10.4	7.8	13.5	18.7	16.5	14.1	16.3	
@ 30 VOLT INPUT	7.0	13.0	9.7	17.0	24.8	20.7	17.7	30.5	
INPUT CURRENT	8.3 mA @ 6 Volt input to 52 mA @ 30 Volt input								
² NON-LINEARITY	$\pm 0.5\%$ Full Scale Over Total Working Range								
	$\pm 1.0\%$ Full Scale Over Maximum Usable Range								
INTERNAL CARRIER FREQUENCY, Hz	13000	12000	3600	3400	3200	1500	1400	1400	
% RIPPLE, RMS (nominal)	0.7	0.7	0.8	0.8	0.8	1	1	1	
OUTPUT IMPEDANCE, Ohms	2500	3500	5200	5500	5600	5500	5600	5600	
FREQ. RESPONSE (3 dB down), Hz	300	140	115	110	100	110	75	75	
TEMPERATURE RANGE	-65°F to +250°F (-54°C to +121°C)								
RESOLUTION	Infinite								

BLOCK DIAGRAM

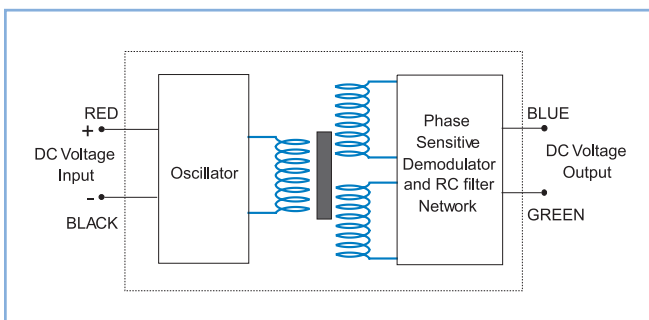

Notes:

1. Polarity of excitation must be observed for proper function. Reversal will not damage the unit.
2. Load Impedance of 50 KOhms minimum required for proper operation.
3. Output polarity will be positive on one side of null, negative on the other side of null. Transducers are calibrated at 24 VDC.
4. Blue lead is more positive with respect to the Green lead when the core is moved toward the lead end.

DIMENSIONAL DIAGRAM

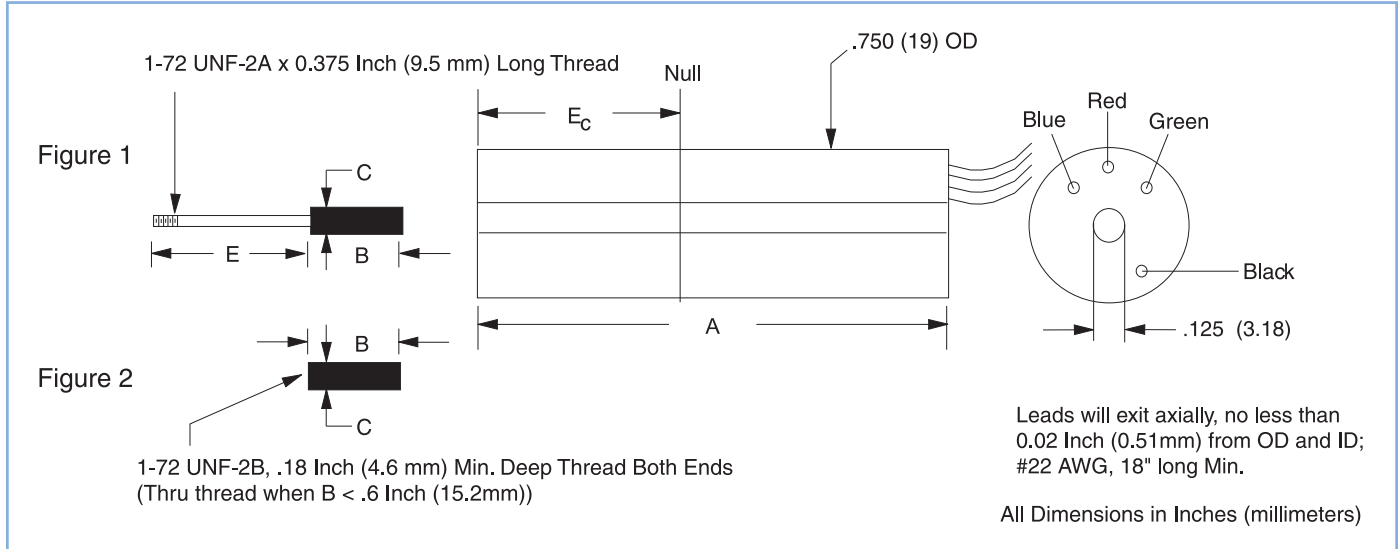

SPECIFICATIONS - MECHANICAL

MODEL*	LINEAR RANGE ±Inches (mm)	BODY LENGTH, A Inches (mm)	ELECTRICAL CENTER, E _c Inches (mm)	BODY MASS Grams	CORE LENGTH, B Inches (mm)	EXTENSION LENGTH, E Inches (mm)
0240-0000__	0.05 (1.27)	0.87 (22.1)	0.34 (8.64)	22	0.56 (14.2)	1.9 (48.3)
0241-0000__	0.10 (2.54)	1.12 (28.5)	0.46 (11.7)	28	0.75 (19.1)	1.9 (48.3)
0242-0000__	0.25 (6.35)	3.21 (81.5)	1.44 (36.6)	70	1.75 (44.5)	1.9 (48.3)
0243-0000__	0.50 (12.7)	3.71 (94.2)	1.69 (42.9)	80	1.87 (47.5)	2.4 (60.9)
0244-0000__	1.00 (25.4)	4.71 (120)	2.19 (55.6)	104	2.00 (50.8)	3.2 (81.2)
0245-0000__	2.00 (50.8)	8.21 (209)	3.94 (100)	180	3.50 (88.9)	5.2 (132)
0246-0000__	3.00 (76.2)	10.52 (267)	5.09 (129)	220	3.50 (88.9)	8.4 (213)
0246-00005	4.00 (101.6)	10.52 (267)	5.09 (129)	220	2.00 (50.8)	9.1 (231)

* Model numbers ending with a “_” have multiple core options. All standard units will end with a **0** indicating a core assembly. This core assembly consists of a core brazed to an extension rod that terminates in 1-72 UNF-2A threads. If an option is not selected, option **0** will be provided.

The core is constructed from a soft, high permeability iron-nickel alloy. Nonmagnetic stainless steel is used as extension rod material. Core assemblies are sized for use over the maximum working range of the LVDT. The difference between option **0** and **1** is the core outer diameter. Smaller O.D. cores should be considered for applications with some radial movement to prevent contacting the inner diameter of the coils. The smaller core diameter will decrease sensitivity slightly (<5%).

Options **2** and **3** are cores only, tapped at both ends with 1-72 UNF-2B threads, as shown in Figure 2 of the Dimensional Drawing. These should be used in applications when a separate extension rod is desirable. The difference between option **2** and **3** is the outer diameter.

The Model 0246-00005 has only one core assembly available. This unit is designed to operate over the maximum usable stroke of ±4.0 inches (±102 mm).

CORE OPTIONS

MODEL	Core Assembly Ref Fig. 1		Threaded Core Ref Fig. 2	
	OPTION 0	OPTION 1	OPTION 2	OPTION 3
	C = 0.120" (3.05mm)	C = 0.099" (2.51mm)	C = 0.120" (3.05mm)	C = 0.099" (2.51mm)
0240-0000__	C004-0000	C004-0001	C005-0002	C005-0003
0241-0000__	C004-0004	C004-0005	C005-0009	C005-0010
0242-0000__	C004-0010	C004-0006	C005-0054	C005-0051
0243-0000__	C004-0011	C004-0007	C005-0035	C005-0023
0244-0000__	C004-0012	C004-0008	C005-0048	C005-0052
0245-0000__	C004-0013	C004-0009	C005-0053	C005-0033
0246-0000__	C004-0014	C004-0015	C005-0053	C005-0033
0246-00005	C004-0057	N/A	N/A	N/A

SERIES 240 MODIFIED FOR USE IN HIGH PRESSURE ENVIRONMENTS

The high pressure version of the Series 240 is suitable for operation in nonconductive and noncorrosive fluids or gasses at pressures up to 5,000 P.S.I. The vented housing eliminates

pressure differentials between the environment and the transducer's interior, allowing rapid and extreme pressure changes without damage or degradation in performance.

DIMENSIONAL DIAGRAM

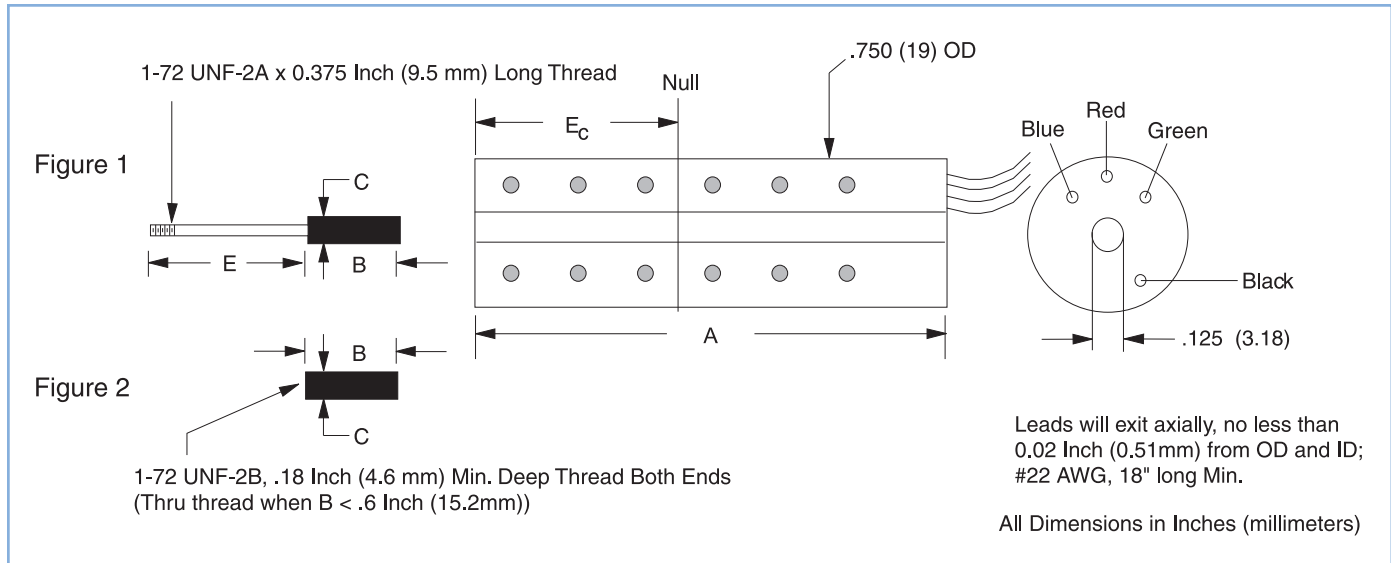

MODEL *	STROKE ±Inches (mm)
0240-0008_	0.050 (1.27)
0241-0007_	0.100 (2.54)
0242-0006_	0.25 (6.35)
0243-0009_	0.50 (12.7)
0244-0014_	1.00 (25.4)
0245-0007_	2.00 (50.8)
0246-0008_	3.00 (76.2)

Note: All electrical and physical specifications are the same as the standard Series 240 LVDTs.

* Model numbers ending with a “_” have multiple core options. All standard units will end with a 0 indicating a core assembly. This core assembly consists of a core brazed to an extension rod that terminates in 1-72 UNF-2A threads. If an option is not selected, option 0 will be provided.

SALES OPTIONS

Option #	Description
X0001	Splashproof - protects the unit from washdown environments or outdoor applications by means of an additional washer on the non-lead end. Applies to Models 0242-0000_ through 0246-0000_
X0004	Modify length of the extension rod to user specified length; specify as Dimension E
X0007	Provide maximum non-linearity of $\pm 0.25\%$ full scale
X0010	Cable termination; eight feet of 4 conductor, 22 AWG, PVC cable; temperature range changes to 0°F to +175°F (-17°C to +79°C)
X0011	Provide an offset and scaled output voltage; special connector and mating connector included; used only with load impedances of 1 Megohm or greater; input voltage and scaling parameters must be specified.
X0023	Install second brazed extension rod
X0025	Terminate in an integral connector type MS3101A-14S-5P; adaptor for connector has 1.00" O.D; includes mating connector

X0025

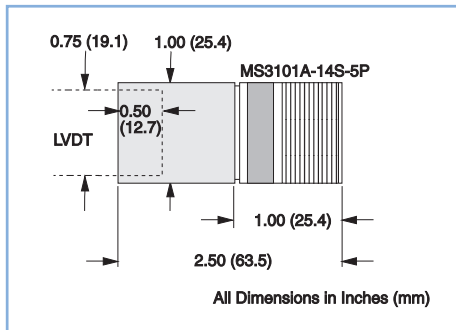

X0036:	Welded non-lead end for enhanced splashproofing; applies to Models 0242-0000_ through 0246-0000_
X0040:	Cable termination - extended temperature range; eight feet of 4 conductor, 22 AWG, Teflon cable; temperature range increased to -65°F to +250°F (-55°C to +121°C)

For more detailed information about these options, please contact the factory.