

## Vert-X 31E - 5V / SSI

### Applications

- Concrete pump
- E-Motor feedback system
- Fork lift

### Features

- High protection class IP68
- Compact dimensions
- Very fast, non-contacting measuring method
- Very long life
- Applications under adverse ambient conditions possible (humidity, dampness, dust, vibrations etc.)
- Low temperature coefficient of the output signal

<b>Sensor principle</b>		<b>MH-X2</b>
<b>Electrical data</b>		
Measuring range	°	0 ... 360
Indep. linearity (without misalignment)	%	±0.5
Indep. linearity (without allowed misalignment @ 360°)	%	±1
Max. hysteresis	°	0.5
Resolution	bit	12
Max. repeatability	°	0.35
Max. temperature coefficient of the output signal	ppm/°K	5
Power supply voltage	VDC	5 (±10%)
Reverse polarity protection of power supply		no
Redundancy feasible		no
<b>Output driver TTL</b>		
MTTFd / MTBF	years	715 / 715
Current consumption without load (typ.)	mA	18
Recommended ohmic load at output	kOhm	1
Max. capacitive load at output	nF	-
Electrical connection		Cable 4pole
Cross section of single wires	mm <sup>2</sup>	0.35 (AWG22)
<b>Output driver Differential RS-485</b>		
MTTFd / MTBF	years	654 / 654
Current consumption without load (typ.)	mA	58
Recommended ohmic load at output	kOhm	0.12
Max. capacitive load at output	nF	-
Electrical connection		Cable 6pole
Cross section of single wires	mm <sup>2</sup>	0.25 (AWG24)
<b>Mechanical data</b>		
Mechanical angle	°	360 (continuous)
Protection class		IP68
Min. life	movements	no limitation
Operating & storage temperature	°C	-40 ... +85
IEC 68-2-6 Vibration (Amax = 0.75mm, f = 5 ... 2000 Hz)	g	50
IEC 68-2-27 Shock	g	200
<b>Standards</b>		
EN 55022 class B, Emission radiated (30... 230 MHz)	dB(μV/m)	max. 30
EN 55022 class B, Emission radiated (230...1000MHz)	dB(μV/m)	max. 37
EN 61000-4-2, ESD (contact discharge / air discharge)	kV	±4 / ±8
EN 61000-4-3, Immision HF radiated (80... 1000 MHz)	V/m	30
EN 61000-4-4, Burst (on all lines)	kV	±1
EN 61000-4-5, Surge (lines to ground)	kV	±1
EN 61000-4-6, Immision HF conducted (0.15...80MHz)	Vemk	10
EN 61000-4-8, Immision magnetic field (50Hz)	A/m	300
IEC 60393-1 Insulation resistance (500VDC, 1bar, 2s)	GOhm	20
IEC 60393-1 Dielectric strength (VAC, 50Hz, 1min, 1bar)	kV	1

Errors and omissions excepted. Subject to change without notice. / State: 22.05.13

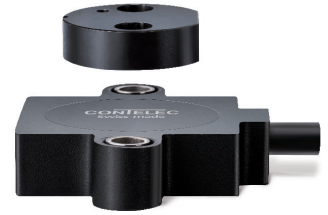

**Vert-X 31E - 5V / SSI**  
**Ordering code**

												<b>Output characteristics / Output driver</b>			<b>Electrical connection</b>		
												TTL Standard 1			6 Optional Cable 6pole		
												Differential RS-485 Optional 3			8 Standard Cable 4pole		
															9 Optional Special cable		
												<b>Output signal</b>			<b>Length of cable</b>		
												SSI Standard 6			02 Standard 1.0m		
															06 Optional 3.0m		
															10 Optional 5.0m		
															99 Optional Special length		
												<b>Power supply voltage</b>					
												5VDC Standard 2					
<b>Vert-X</b>	<b>3</b>	<b>1</b>	<b>E</b>	<b>5</b>	<b>a</b>	<b>6</b>	<b>3</b>	<b>6</b>	<b>2</b>	<b>6</b>	<b>1</b>	<b>8</b>	<b>0</b>	<b>2</b>			
												<b>Electrical angle</b>					
												36 Standard			Electrical angle 360°		
												<b>Sensor principle</b>					
												6 MH-X2					
												<b>Mounting hole</b>					
												a Standard Through-hole ø 4.4mm					
												b Optional Through-hole ø 4.4mm with counterbore ø 7.4mm					
												<b>Mechanical version</b>					
												31E5 Standard Magnetic actuator type 5					
												31E6 Standard Magnetic actuator type 6					
												31E7 Optional Magnetic actuator type 7					
												31E9 Optional Special magnetic actuator					

	<b>MH-X2</b>
Custom magnetic actuator	X
Custom cable	X

**Options (on request)**

Errors and omissions excepted. Subject to change without notice. / State: 22.05.13



**Vert-X 31E5axxx xxx xxx**

**Accessoires (incl.)**

- None

**Working position (Z) and max. permitted misalignment of the magnetic actuator**

see mounting information

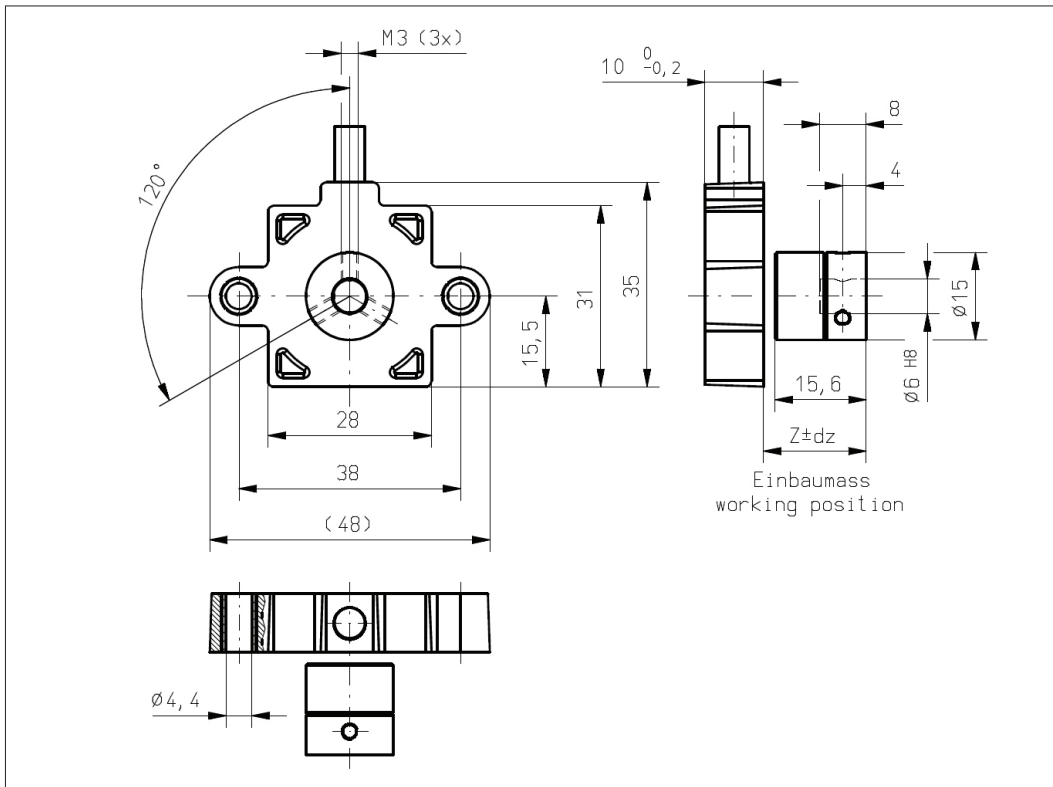

**Vert-X 31E5bxxx xxx xxx**

**Accessoires (incl.)**

- None

**Working position (Z) and max. permitted misalignment of the magnetic actuator**

see mounting information

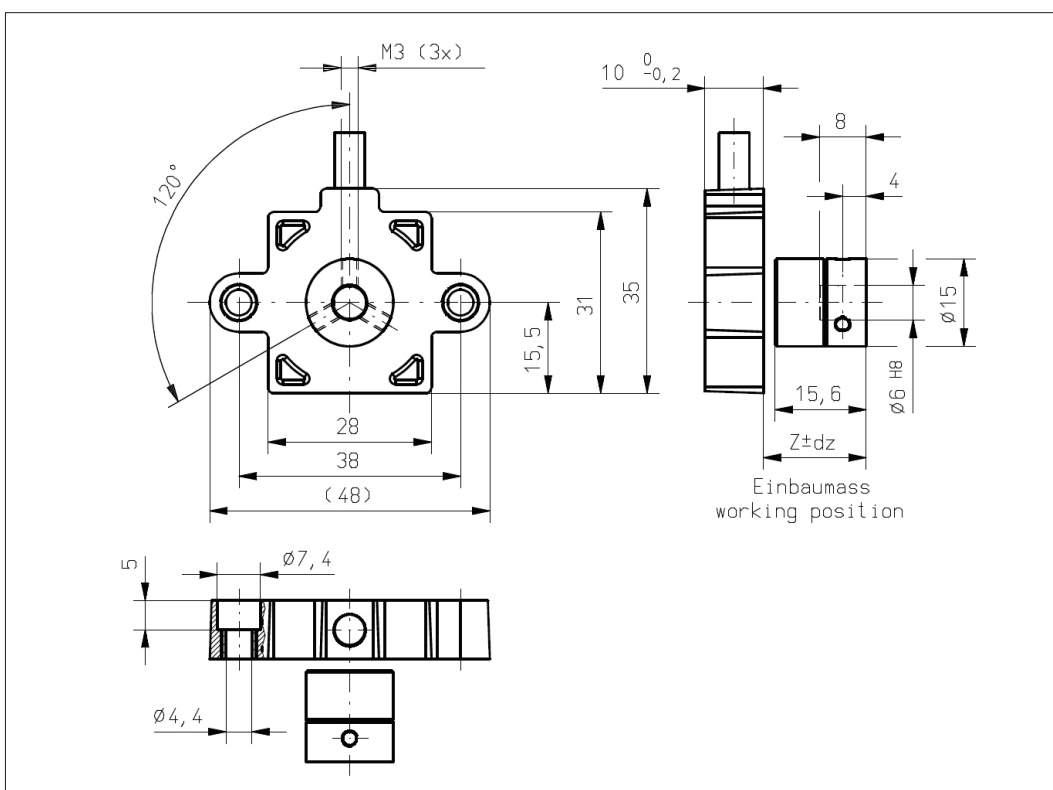

Errors and omissions excepted. Subject to change without notice. / State: 22.05.13

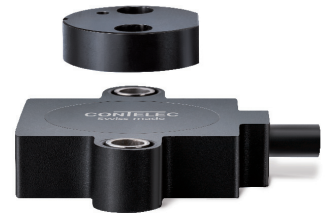

### Vert-X 31E6axxx xxx xxx

#### Accessoires (incl.)

- None

**Working position (Z) and max. permitted misalignment of the magnetic actuator**

see mounting information

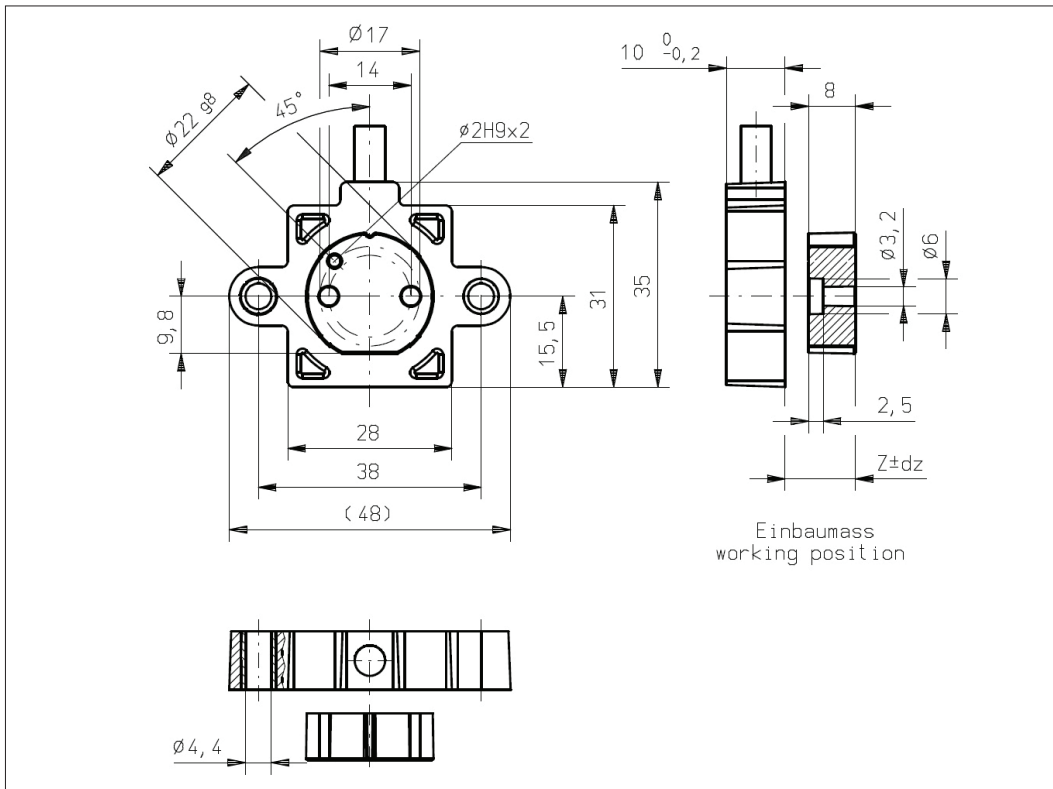

### Vert-X 31E6bxxx xxx xxx

#### Accessoires (incl.)

- None

**Working position (Z) and max. permitted misalignment of the magnetic actuator**

see mounting information

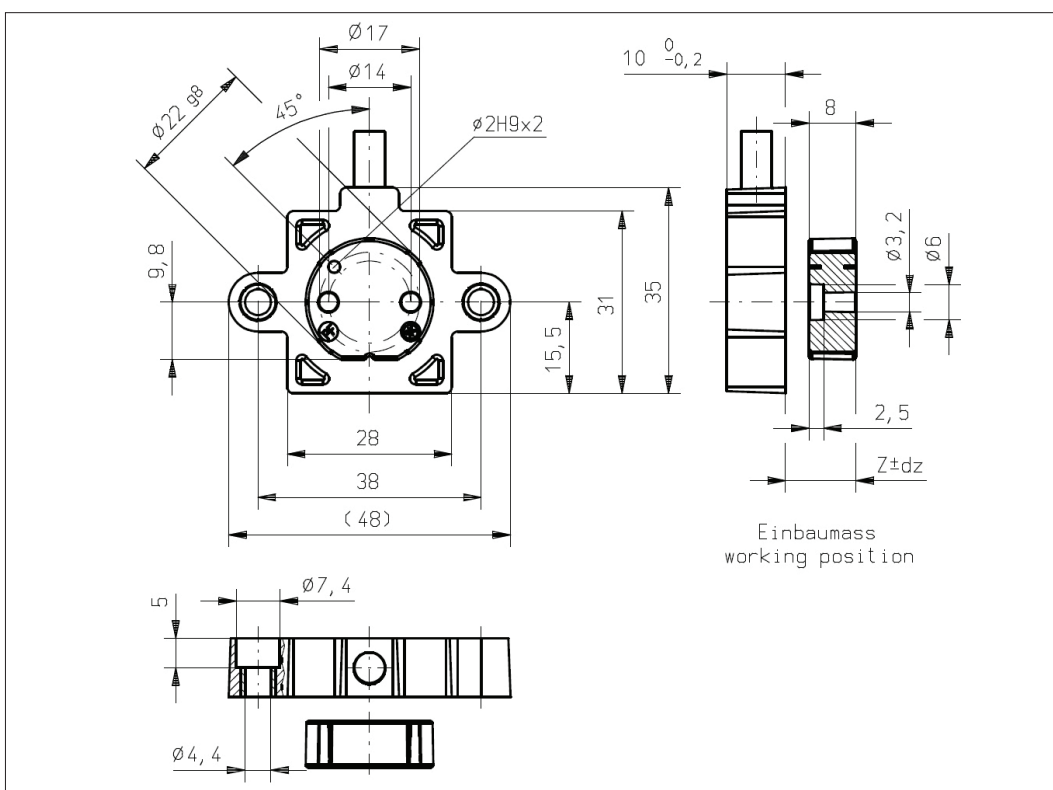

Errors and omissions excepted. Subject to change without notice. / State: 22.05.13

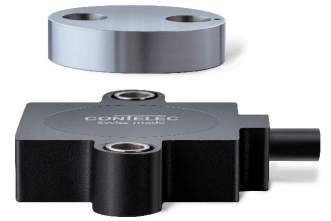

**Vert-X 31E7axxx xxx xxx**

**Accessoires (incl.)**

- None

**Working position (Z) and max. permitted misalignment of the magnetic actuator**

see mounting information

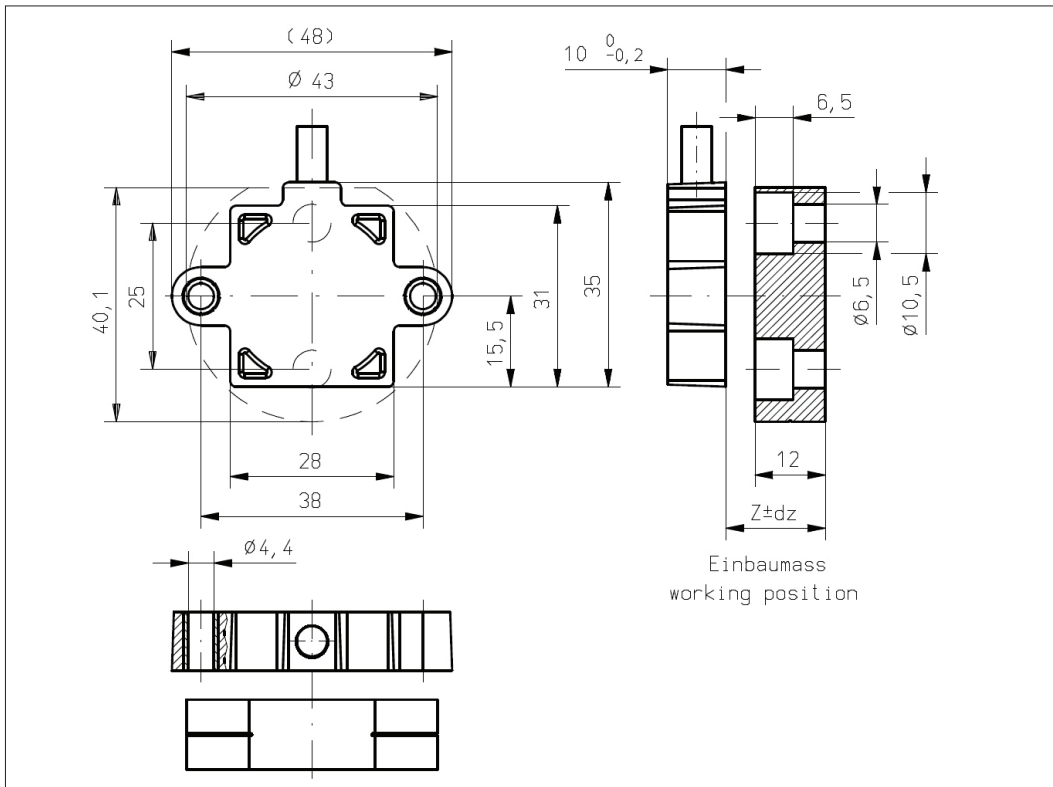

**Vert-X 31E7bxxx xxx xxx**

**Accessoires (incl.)**

- None

**Working position (Z) and max. permitted misalignment of the magnetic actuator**

see mounting information

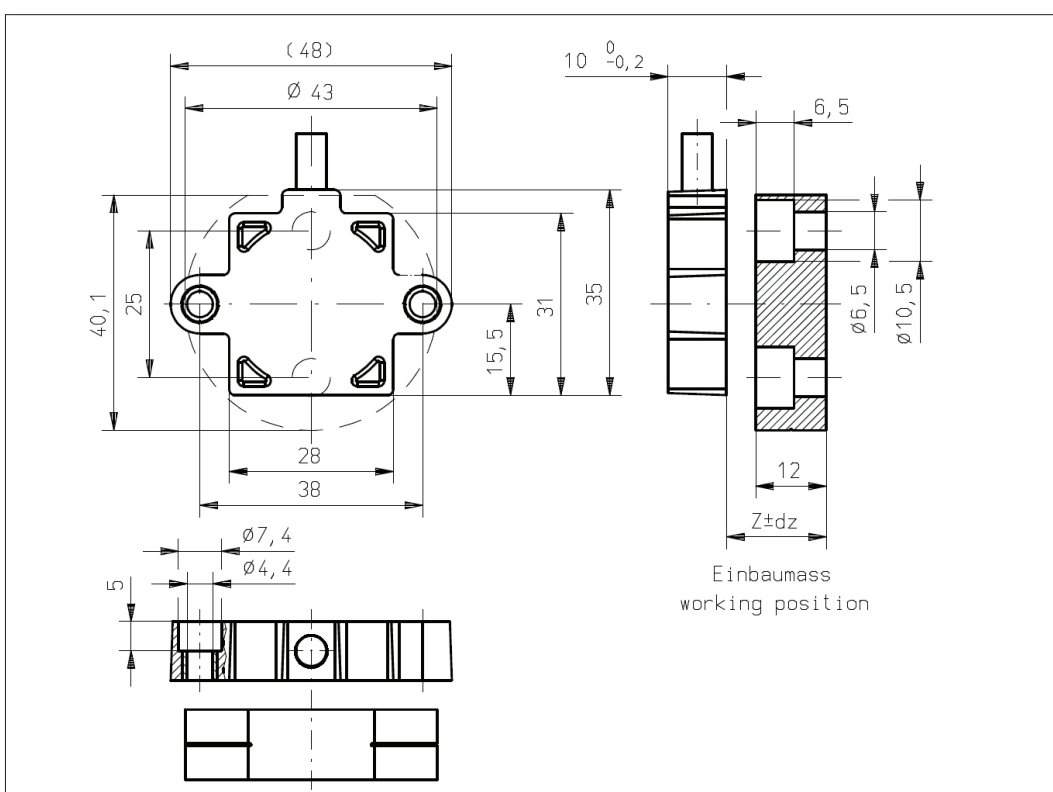

Errors and omissions excepted. Subject to change without notice. / State: 22.05.13

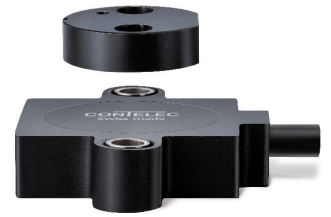

### Vert-X 31E5

#### Mounting information

**Working position (Z)**  
MH-X2 16.10mm

#### Max. permitted misalignment of the magnetic actuator

dx	±0.50mm
dy	±0.50mm
dz	±0.30mm

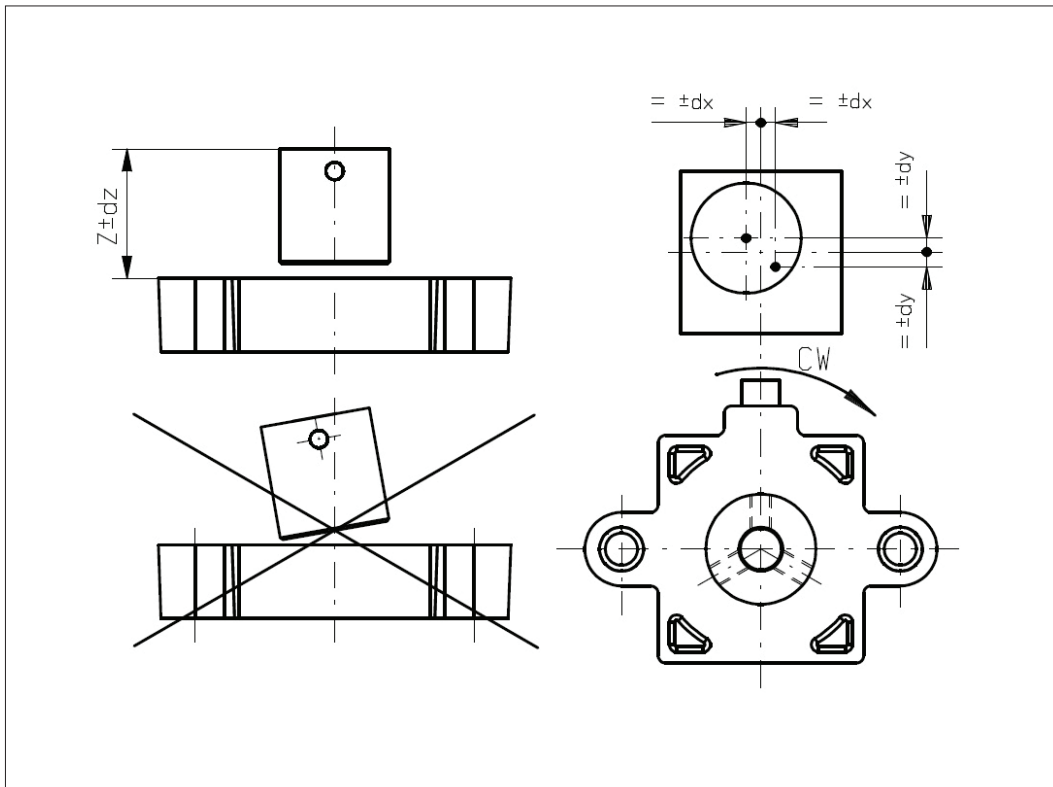

### Vert-X 31E6

#### Mounting information

**Working position (Z)**  
MH-X2 8.70mm

#### Max. permitted misalignment of the magnetic actuator

dx	±0.50mm
dy	±0.50mm
dz	±0.50mm

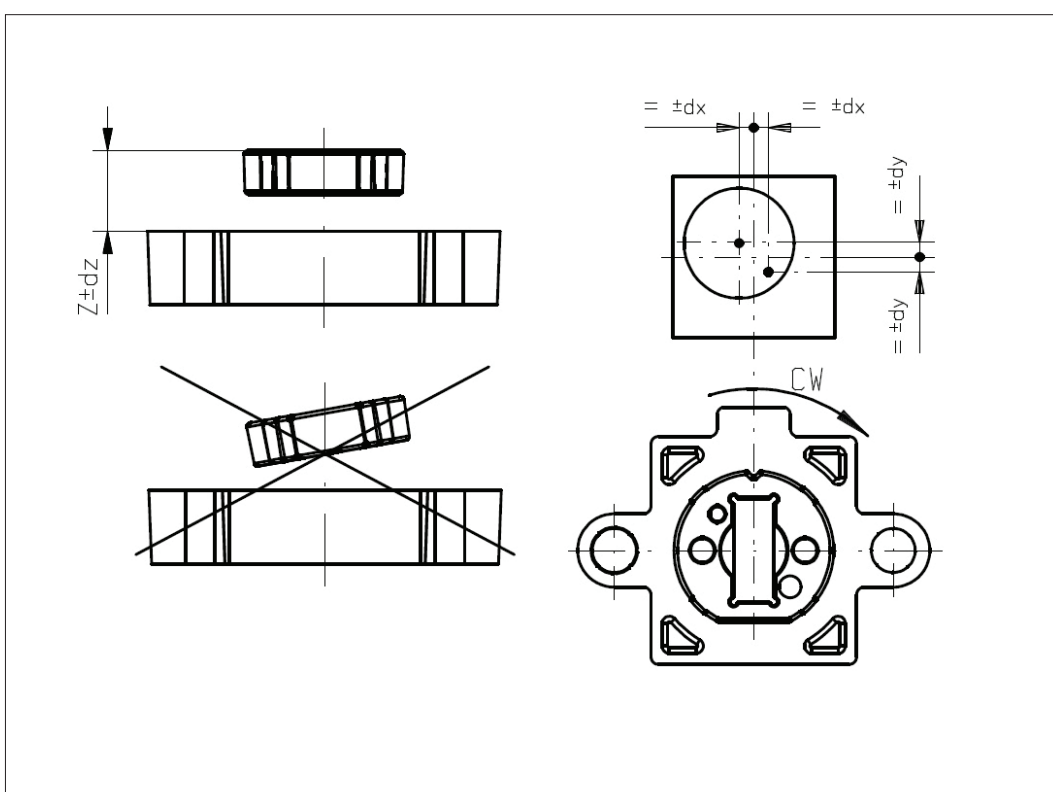

Errors and omissions excepted. Subject to change without notice. / State: 22.05.13

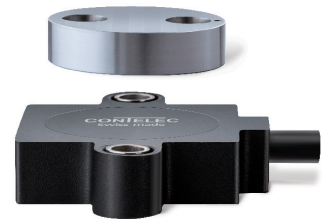

### Vert-X 31E7

#### Mounting information

**Working position (Z)**  
MH-X2 13.00mm

#### Max. permitted misalign- ment of the magnetic actuator

dx	±1.00mm
dy	±1.00mm
dz	±0.80mm

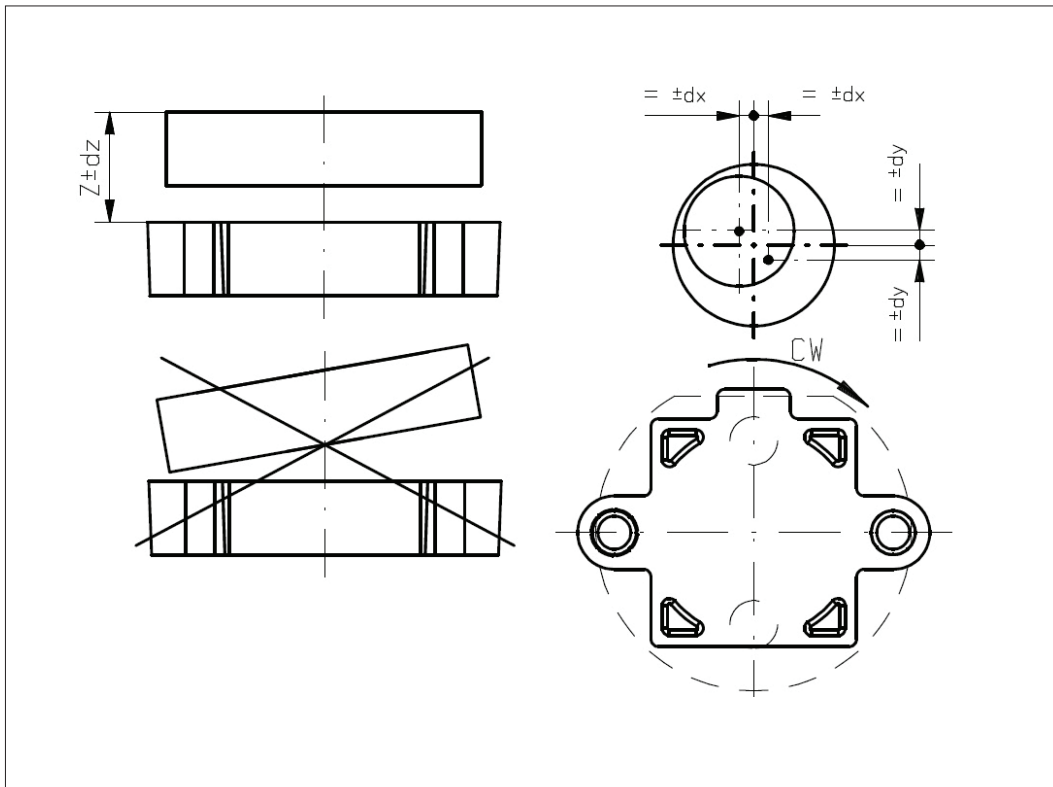

Errors and omissions excepted. Subject to change without notice. / State: 22.05.13